

# ***Countdown Chapter 10***

## ***Clothing***

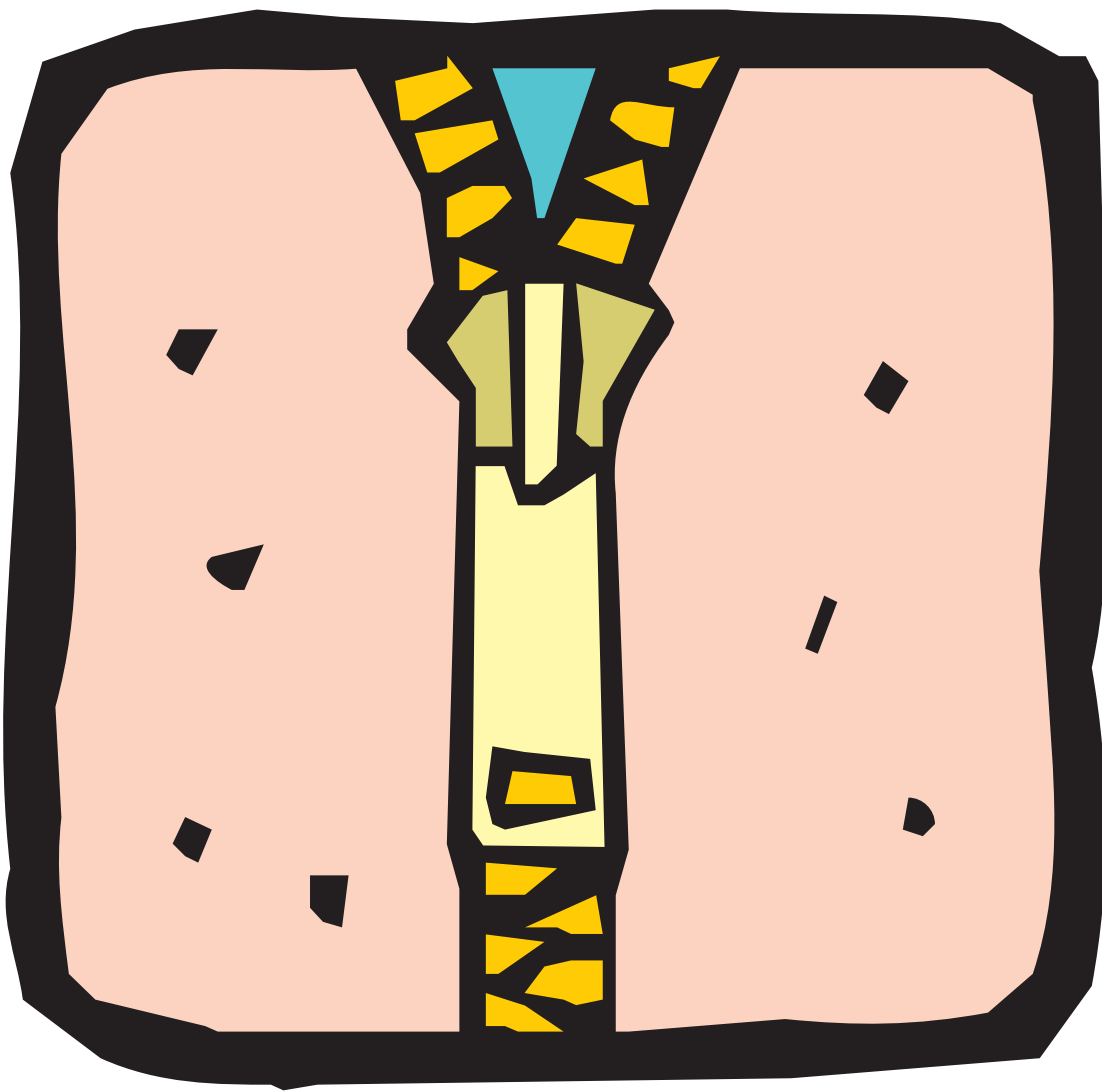

# ***Countdown Chapter 10***

## ***Clothing***

### ***Contents***

Ready, Let's Sew .....	1
What's in the Sewing Box? .....	3
The Parts of the Sewing Machine .....	5
The Functions of the Sewing Machine .....	7
The Seven Clues to Achieve a Total Look .....	9

# Clothing

## Ready, Let's Sew

Find the clothing and sewing words in the word search puzzle. The words go up, down, across, and diagonally. Some are spelled backwards.

label	press	fabric	pattern	topstitch
fuse	grooming	scissors	pins	stitch
hem	slip stitch	sewing machine	seam	needle
appliqué	seven clues	button	measure	care label

## Word Search

### In this activity you will:

- identify terms used when making 4-H clothing projects.
- identify sewing equipment terms used when making 4-H outfits.

iron	marking pencil
hem gauge	thread

n	r	e	t	t	a	p	b	h	d	f	f	x	s	q
c	a	p	p	l	i	q	u	e	s	t	i	t	c	h
g	k	m	e	s	u	f	z	m	e	a	s	u	r	e
d	p	n	b	n	o	r	i	g	d	x	n	v	s	f
b	s	e	w	i	n	g	m	a	c	h	i	n	e	a
s	s	e	r	p	f	i	r	u	s	b	k	f	e	b
c	g	d	v	a	i	m	k	g	j	c	s	s	f	r
i	e	l	t	e	c	a	r	e	l	a	b	e	l	i
s	p	e	h	d	n	g	r	o	o	m	i	n	g	c
s	h	m	r	w	f	c	h	b	o	b	c	h	j	l
o	m	a	e	s	c	m	l	e	a	o	t	u	y	a
r	r	l	a	d	q	e	b	u	t	t	o	n	n	b
s	o	x	d	d	e	h	a	r	e	q	n	t	s	e
s	z	e	g	g	h	c	t	i	t	s	p	o	t	l
m	a	r	k	i	n	g	p	e	n	c	i	l	c	r
e	s	a	h	c	t	i	t	s	p	i	l	s	a	n

Developed by: Mary Forster, Extension Associate, 4-H Youth Development/Family and Consumer Sciences

# Clothing

## Ready, Let's Sew

Find the clothing and sewing words in the word search puzzle. The words go up, down, across, and diagonally. Some are spelled backwards.

label	press	fabric	pattern	topstitch		
fuse	grooming	scissors	pins	stitch		
hem	slip stitch	sewing machine	seam	needle	iron	marking pencil
appliqué	seven clues	button	measure	care label	hem gauge	thread

### Word Search—Key

#### In this activity you will:

- identify terms used when making 4-H clothing projects.
- identify sewing equipment terms used when making 4-H outfits.

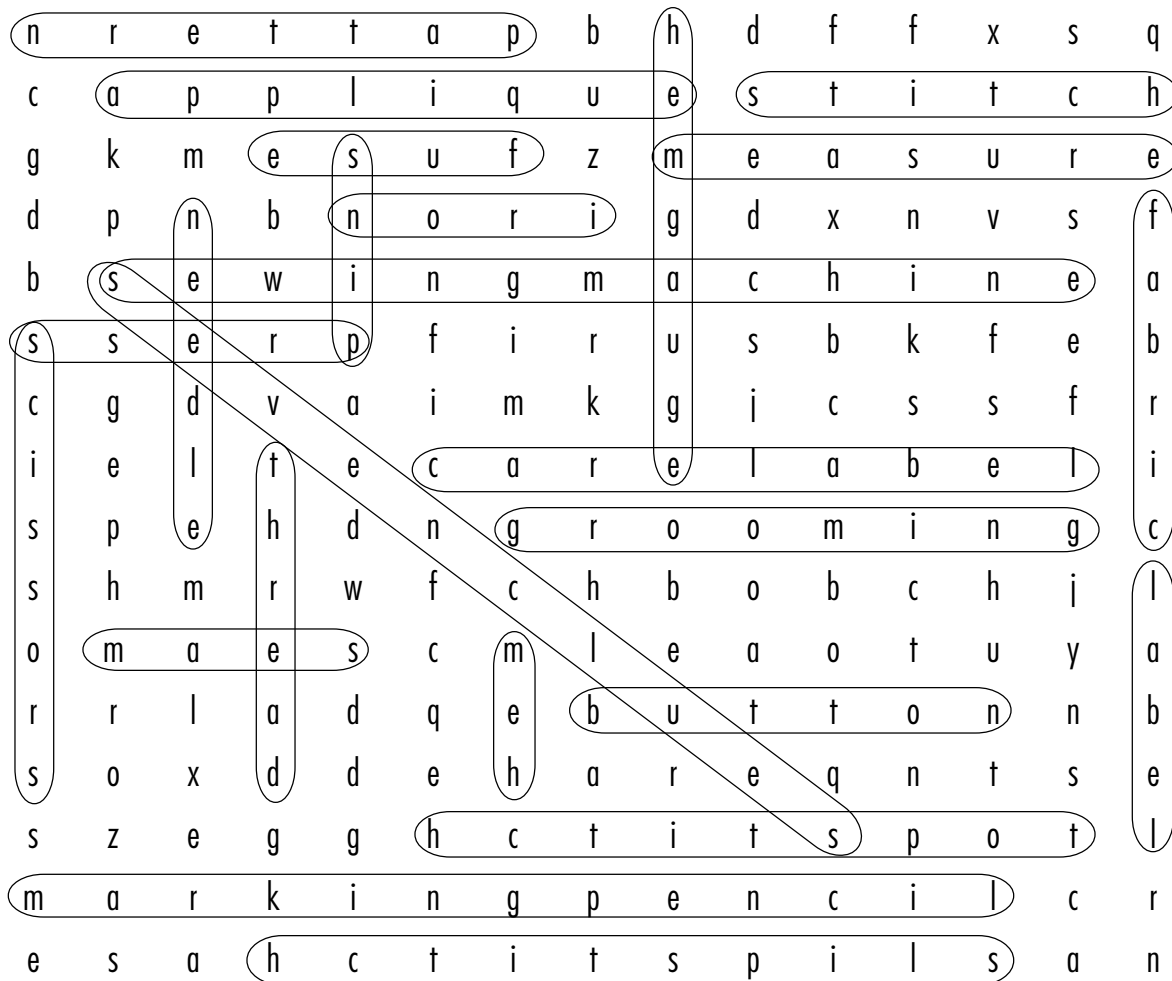

Developed by: Mary Forster, Extension Associate, 4-H Youth Development/Family and Consumer Sciences

# Clothing

## What's in the Sewing Box?

Match each term with its correct definition by writing the letter of the term in front of the correct definition.

### Definitions

- \_\_\_\_\_ 1. keeps sewing tools in one place
- \_\_\_\_\_ 2. used to cut fabric
- \_\_\_\_\_ 3. used to take body measurements and to measure fabric
- \_\_\_\_\_ 4. used to measure short distances
- \_\_\_\_\_ 5. used for hand sewing
- \_\_\_\_\_ 6. used to hold pieces of fabric together or to hold patterns to fabric
- \_\_\_\_\_ 7. stores pins
- \_\_\_\_\_ 8. used to transfer important markings from the pattern onto the fabric
- \_\_\_\_\_ 9. keeps the needle from hurting your finger when sewing by hand
- \_\_\_\_\_ 10. used in sewing stitches to hold fabric together
- \_\_\_\_\_ 11. used to remove stitching mistakes
- \_\_\_\_\_ 12. used to cut single or multiple layers of fabric; must be used with special cutting mat

## Matching

### In this activity you will:

- learn the names of the basic sewing tools needed for making 4-H clothing projects.
- learn the uses of each sewing tool.

### Word List

- A. pin cushion
- B. seam ripper
- C. rotary cutter
- D. thimble
- E. hem gauge
- F. marking tools
- G. sewing box
- H. pins
- I. needles
- J. shears
- K. thread
- L. tape measure

# Clothing

## What's in the Sewing Box?

Match each term with its correct definition by writing the letter of the term in front of the correct definition.

### Definitions

- G**   1. keeps sewing tools in one place
- J**   2. used to cut fabric
- L**   3. used to take body measurements and to measure fabric
- E**   4. used to measure short distances
- I**   5. used for hand sewing
- H**   6. used to hold pieces of fabric together or to hold patterns to fabric
- A**   7. stores pins
- F**   8. used to transfer important markings from the pattern onto the fabric
- D**   9. keeps the needle from hurting your finger when sewing by hand
- K**   10. used in sewing stitches to hold fabric together
- B**   11. used to remove stitching mistakes
- C**   12. used to cut single or multiple layers of fabric; must be used with special cutting mat

## Matching—Key

### In this activity you will:

- learn the names of the basic sewing tools needed for making 4-H clothing projects.
- learn the uses of each sewing tool.

### Word List

- A. pin cushion
- B. seam ripper
- C. rotary cutter
- D. thimble
- E. hem gauge
- F. marking tools
- G. sewing box
- H. pins
- I. needles
- J. shears
- K. thread
- L. tape measure

# Clothing

## The Parts of the Sewing Machine

Look at the drawing of a sewing machine. How many parts do you already know? Fill in as many parts as you know and then turn the page to check your answers.

### Identification

**In this activity you will:**

- identify the sewing machine parts.

A. \_\_\_\_\_

D. \_\_\_\_\_

G. \_\_\_\_\_

B. \_\_\_\_\_

E. \_\_\_\_\_

H. \_\_\_\_\_

C. \_\_\_\_\_

F. \_\_\_\_\_

I. \_\_\_\_\_

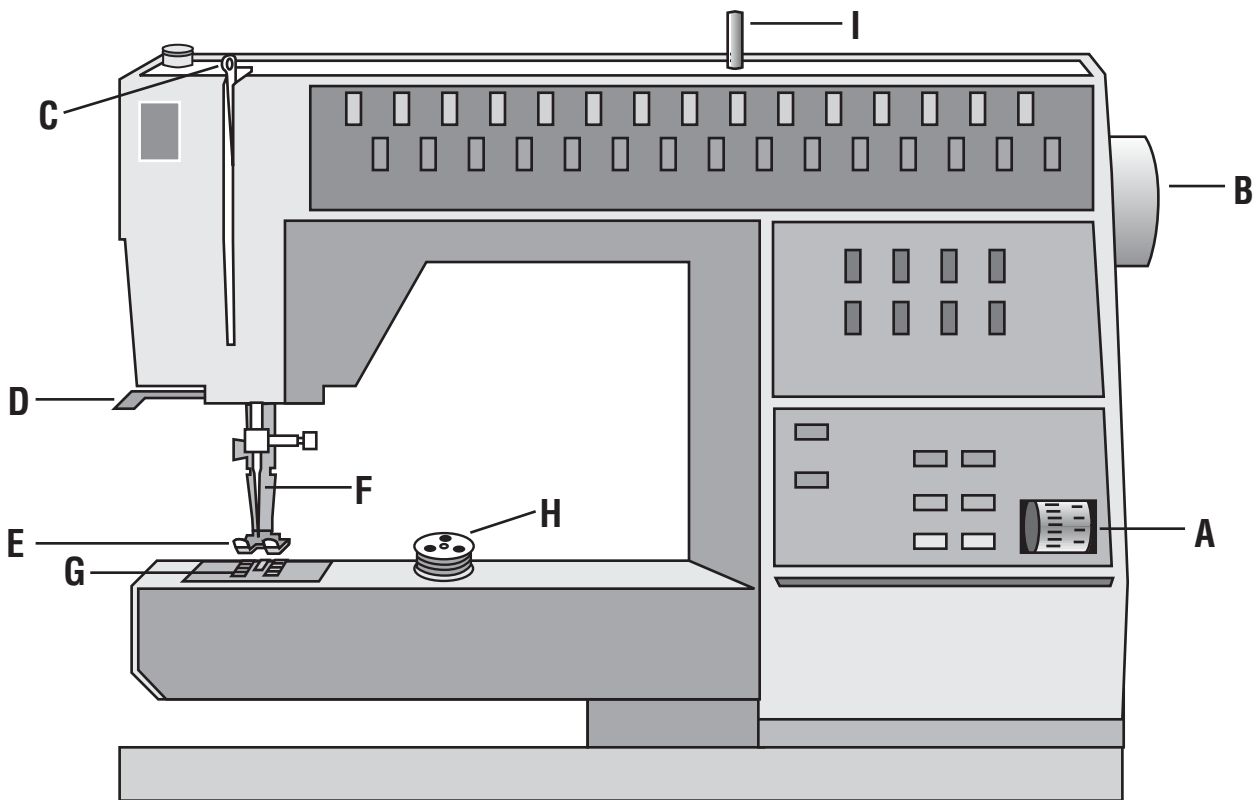

After completing this activity, find these parts on your own sewing machine. Do some of the parts of your machine look different than the picture?     Yes     No

Which parts? \_\_\_\_\_  
\_\_\_\_\_  
\_\_\_\_\_

*Developed by: Mary Forster, Extension Associate, 4-H Youth Development/Family and Consumer Sciences*

# Clothing

## The Parts of the Sewing Machine

Look at the drawing of a sewing machine. How many parts do you already know? Fill in as many parts as you know and then turn the page to check your answers.

### Identification—Key

In this activity you will:

- identify the sewing machine parts.

A. stitch length adjustment

B. balance wheel

C. thread takeup lever

D. presser bar lever

E. presser foot

F. needle

G. feed dog

H. bobbin

I. spool pin

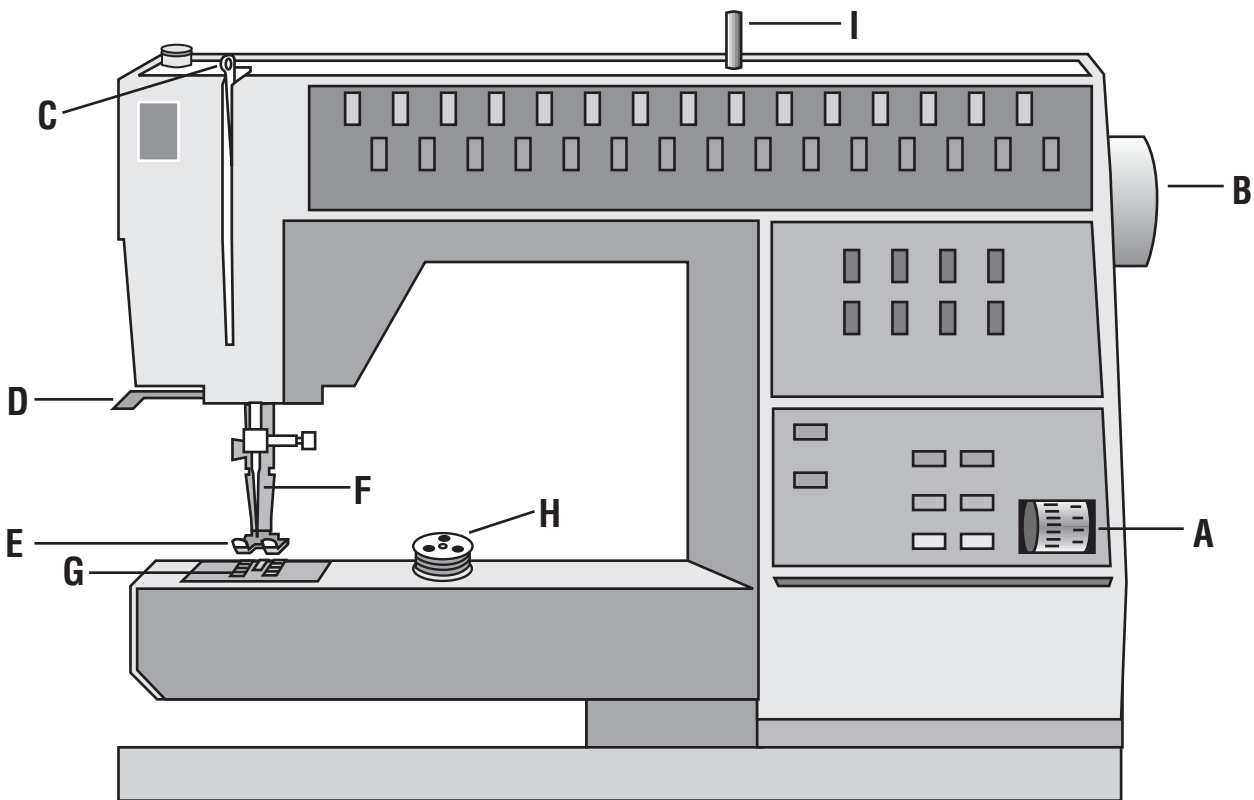

After completing this activity, find these parts on your own sewing machine. Do some of the parts of your machine look different than the picture?  Yes  No

Which parts? **Answers will vary.**

---



---

Developed by: Mary Forster, Extension Associate, 4-H Youth Development/Family and Consumer Sciences



# Clothing

## The Functions of the Sewing Machine

Match the correct name of the sewing machine part with the the function it serves when sewing a garment. Place the letter of the correct answer in the blank provided.

### Matching

**In this activity you will:**

- learn what each part of the sewing machine does.

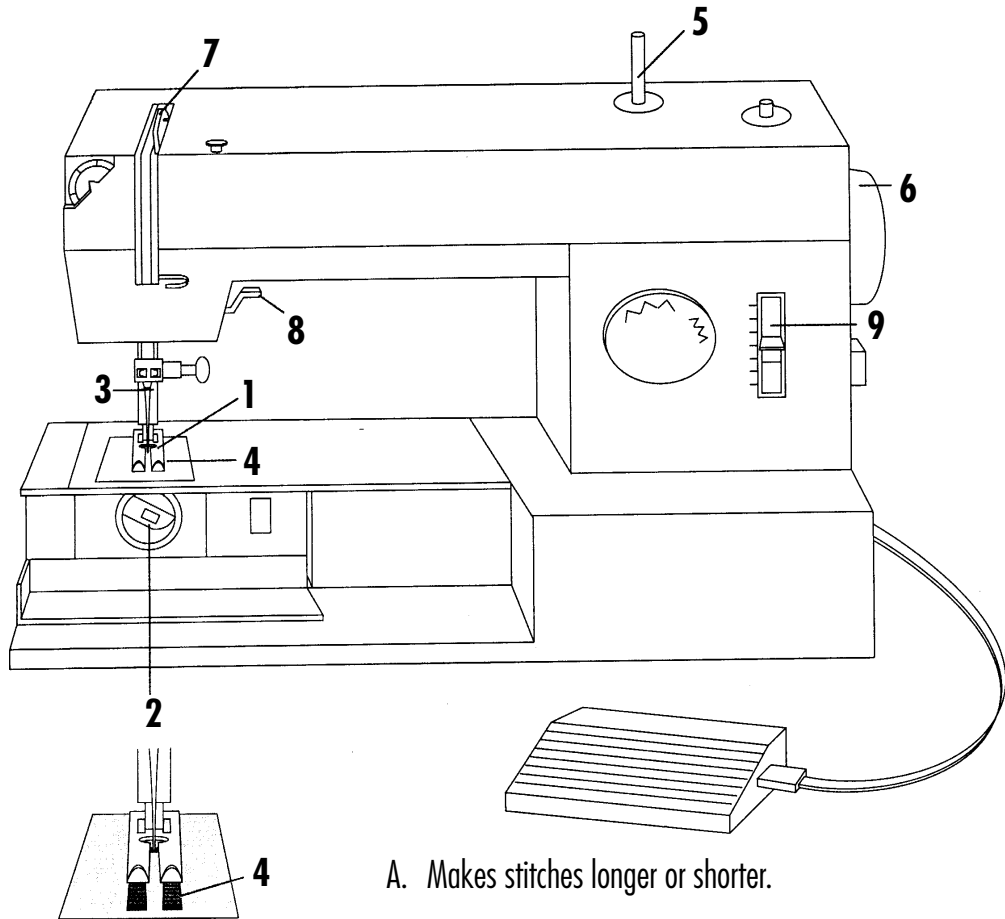

\_\_\_\_\_ 1. Presser foot

\_\_\_\_\_ 2. Bobbin

\_\_\_\_\_ 3. Needle

\_\_\_\_\_ 4. Feed dog

\_\_\_\_\_ 5. Spool pin

\_\_\_\_\_ 6. Balance wheel

\_\_\_\_\_ 7. Thread takeup lever

\_\_\_\_\_ 8. Presser bar lever

\_\_\_\_\_ 9. Stitch length adjustment

A. Makes stitches longer or shorter.

B. Holds the spool of thread in place.

C. Small teeth that move fabric to needle as you sew.

D. Holds the fabric in place as you sew.

E. Moves up and down guiding the upper thread to the needle.

F. Carries the top thread to make stitches.

G. Helps the needle run up and down smoothly.

H. Holds the thread for the underside of the seam.

I. Raises and lowers the presser foot.

*Developed by: Mary Forster, Extension Associate, 4-H Youth Development/Family and Consumer Sciences*

# Clothing

## The Functions of the Sewing Machine

Match the correct name of the sewing machine part with the the function it serves when sewing a garment. Place the letter of the correct answer in the blank provided.

### Matching—Key

In this activity you will:

- learn what each part of the sewing machine does.

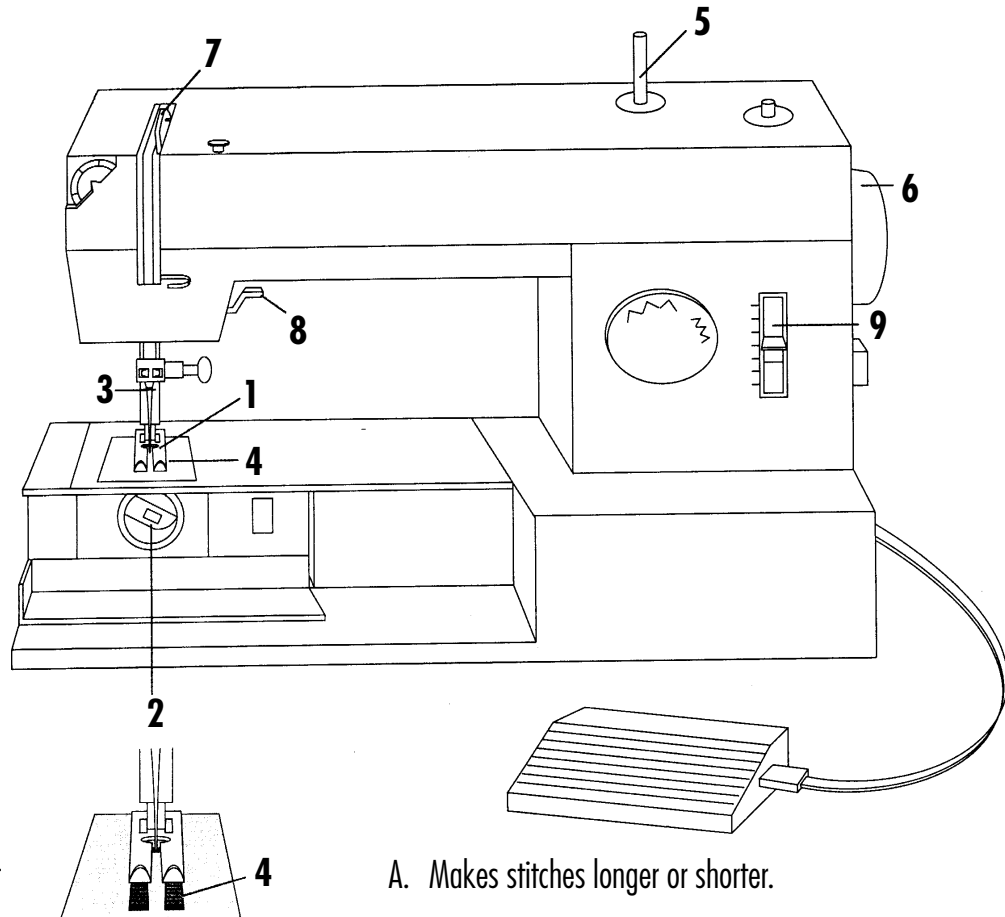

  D   1. Presser foot

  H   2. Bobbin

  F   3. Needle

  C   4. Feed dog

  B   5. Spool pin

  G   6. Balance wheel

  E   7. Thread takeup lever

  I   8. Presser bar lever

  A   9. Stitch length adjustment

A. Makes stitches longer or shorter.

B. Holds the spool of thread in place.

C. Small teeth that move fabric to needle as you sew.

D. Holds the fabric in place as you sew.

E. Moves up and down guiding the upper thread to the needle.

F. Carries the top thread to make stitches.

G. Helps the needle run up and down smoothly.

H. Holds the thread for the underside of the seam.

I. Raises and lowers the presser foot.

*Developed by: Mary Forster, Extension Associate, 4-H Youth Development/Family and Consumer Sciences*

# Clothing

## The Seven Clues to Achieve a Total Look

Unscramble these words that are the seven clues to achieving a total look.

- niohfas \_\_\_\_\_
- siedng \_\_\_\_\_
- ift \_\_\_\_\_
- nsttoirucnoc \_\_\_\_\_
- oomgingr \_\_\_\_\_
- turosep nda esipo \_\_\_\_\_
- lbeaonsrep lituaqies \_\_\_\_\_

### Word Scramble and Matching

**In this activity you will:**

- learn the seven clues to a total look.
- learn how to use the seven clues to achieve the total look in a 4-H clothing project.

Write each of the seven clues in the blank after its correct description below.

1. Is influenced through fabric, color, style, lines, garment, details, accessories, and/or personal presentation.  
\_\_\_\_\_
2. Positive presentation of self, pleasant smile. \_\_\_\_\_
3. Garment is balanced, overall smooth look, hangs on the body correctly. \_\_\_\_\_
4. Total outfit looks “smart” and put together. It is coordinated. Outfit is becoming to wearer. \_\_\_\_\_
5. Body and clothes are clean and neat. \_\_\_\_\_
6. Overall appearance is smooth. The proper techniques are used to have edges of collars smooth, even, and flat. Seams are clipped and trimmed to prevent bulk. Darts are smoothly stitched and pressed. Hem is neat and smooth.  
\_\_\_\_\_
7. The person walks, sits, and stands straight and tall. Movements are easy and smooth.  
\_\_\_\_\_

*Developed by: Mary Forster, Extension Associate, 4-H Youth Development/Family and Consumer Sciences*

# Clothing

## The Seven Clues to Achieve a Total Look

Unscramble these words that are the seven clues to achieving a total look.

niohfas

**fashion**

---

siedng

**design**

---

ift

**fit**

---

nsttoirucnoc

**construction**

---

oomgingr

**grooming**

---

turosep nda esipo

**posture and poise**

---

lbeaonsrep lituaqies

**personable qualities**

---

### Word Scramble and Matching—Key

**In this activity you will:**

- learn the seven clues to a total look.
- learn how to use the seven clues to achieve the total look in a 4-H clothing project.

Write each of the seven clues in the blank after its correct description below.

1. Is influenced through fabric, color, style, lines, garment, details, accessories, and/or personal presentation.

**fashion**

---

2. Positive presentation of self, pleasant smile. **personable qualities**
- 

3. Garment is balanced, overall smooth look, hangs on the body correctly. **fit**
- 

4. Total outfit looks “smart” and put together. It is coordinated. Outfit is becoming to wearer. **design**
- 

5. Body and clothes are clean and neat. **grooming**
- 

6. Overall appearance is smooth. The proper techniques are used to have edges of collars smooth, even, and flat. Seams are clipped and trimmed to prevent bulk. Darts are smoothly stitched and pressed. Hem is neat and smooth.

**construction**

---

7. The person walks, sits, and stands straight and tall. Movements are easy and smooth.

**posture and poise**

---

*Developed by: Mary Forster, Extension Associate, 4-H Youth Development/Family and Consumer Sciences*